



BABY/MOLEPAC STANDS

TYPE 3631 LITEWATE KIT STAND

Designed specifically for many of our kit configurations while also available as a single unit.

MOUNTING: 5/8" dia. standard spud
EXTENSIONS: 3
LOW: 30 3/4 inches
HIGH: 104 1/2 inches
FOLDED FOR STORAGE: 30 inches
WEIGHT: 5 lbs.
FINISH: Clear anodize aluminum
CASTERS: None



TYPE 4811 COMPACT LITEWATE LOW BABY SIZE STAND

A low version of the popular Baby Size Compact Litewate Stand.

MOUNTING: 5/8" dia. standard spud
EXTENSIONS: 2
LOW: 15 3/4 inches
HIGH: 38 7/8 inches
FOLDED FOR STORAGE: 17 3/4 inches
WEIGHT: 2 3/4 lbs.
FINISH: Clear anodize aluminum
CASTERS: None



TYPE 3621 HUSKY BABY STAND

The standard of Husky Baby Size Litewate folding motion picture type stands.

MOUNTING: 5/8" dia. standard spud
EXTENSIONS: 2
LOW: 36 inches
HIGH: 90 3/8 inches
FOLDED FOR STORAGE: 35 1/2 inches
WEIGHT: 6 lbs.
FINISH: Clear anodize aluminum
CASTERS: None



TYPE 2541 COMPACT LITEWATE BABY SIZE STAND

A low version of the popular Baby Size Compact Litewate Stand.

MOUNTING: 5/8" dia. standard spud
EXTENSIONS: 2
LOW: 15 3/4 inches
HIGH: 38 7/8 inches
FOLDED FOR STORAGE: 17 3/4 inches
WEIGHT: 2 3/4 lbs.
FINISH: Clear anodize aluminum
CASTERS: None



TYPE 3641 SUPER HUSKY BABY STAND

The standard of Super Husky Baby Size Litewate folding motion picture type stands. Extension leg extends to a level position on uneven ground.

MOUNTING: 5/8" dia. standard spud
EXTENSIONS: 3
LOW: 44 5/8 inches
HIGH: 136 1/4 inches
FOLDED FOR STORAGE: 44 1/8 inches
WEIGHT: 9 lbs.
FINISH: Clear anodize aluminum
CASTERS: None



TYPE 5603 MOLEPAC LITEWATE FOLDING STAND

Four Sections, anodized aluminum with 5/8 inch diameter spud in top riser.

MOUNTING: 5/8" dia. standard spud
EXTENSIONS: 3
LOW: 27 1/4 inches
HIGH: 115 1/2 inches
FOLDED FOR STORAGE: 29 1/8 inches
WEIGHT: 3 lbs.
FINISH: Red & clear anodize
CASTERS: None

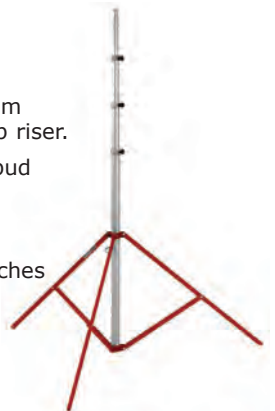



Mole-Richardson Co.

BABY STANDS

TYPE 1391

BABY SIZE LOW

A sturdy but shorter version of the Standard Size Baby Stand, except with one extension.

MOUNTING: $\frac{5}{8}$ " dia. standard spud

EXTENSIONS: 1

LOW: 20 inches

HIGH: 33 inches

FOLDED FOR STORAGE: $18\frac{7}{8}$ inches

WEIGHT: $11\frac{1}{2}$ lbs.

FINISH: Baked maroon enamel

CASTERS: 3 inches



TYPE 40651A

BABY SIZE STANDARD

The standard of Baby Size heavy duty folding motion picture studio type stands.

MOUNTING: $\frac{5}{8}$ " dia. standard spud

EXTENSIONS: 2

LOW: 40 inches

HIGH: 100 inches

FOLDED FOR STORAGE: 39 inches

WEIGHT: $16\frac{1}{2}$ lbs.

FINISH: Baked maroon enamel

CASTERS: 3 inches

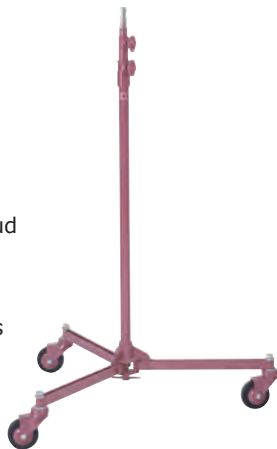

TYPE 1581

BABY SIZE SKY-HI

Designed to reach 62 inches above the Standard Size Baby Stand.

MOUNTING: $\frac{5}{8}$ " dia. standard spud

EXTENSIONS: 4

LOW: 46 inches

HIGH: 162 inches

FOLDED FOR STORAGE: $44\frac{3}{8}$ inches

WEIGHT: 30 lbs.

FINISH: Baked maroon enamel

CASTERS: 4 inches





JUNIOR STANDS

TYPE 500557
JUNIOR SIZE LITEWATE
LOCATION—LESS CASTERS

All aluminum heavy-duty location stand for traveling light. Extension leg extends to a level position on uneven ground.

MOUNTING: 1¹/₈" dia. standard spud
EXTENSIONS: 2
LOW: 30³/₄ inches
HIGH: 57¹/₂ inches
FOLDED FOR STORAGE: 39³/₄ inches
WEIGHT: 9³/₄ lbs.
FINISH: Clear anodize aluminum
CASTERS: None



TYPE 500791
JUNIOR SIZE SKY-HI
LITEWATE LOCATION—
LESS CASTERS

All aluminum heavy-duty location stand. Extension leg extends to a level position on uneven ground.

MOUNTING: 1¹/₈" dia. standard spud
EXTENSIONS: 3
LOW: 58¹/₂ inches
HIGH: 135³/₄ inches
FOLDED FOR STORAGE: 66 inches
WEIGHT: 18³/₄ lbs.
FINISH: Clear anodize aluminum
CASTERS: None
(Type 500569 Caster Kit Available)





Mole-Richardson Co.

JUNIOR STANDS

TYPE 410138 **JUNIOR SIZE STANDARD**

The standard of Junior Size heavy duty folding motion picture studio type stands.

MOUNTING: 1¹/₈" dia. standard spud
EXTENSIONS: 2
LOW: 43 inches
HIGH: 100 inches
FOLDED FOR STORAGE: 39⁷/₈ inches
WEIGHT: 25 lbs.
FINISH: Baked maroon enamel
CASTERS: 4 inches

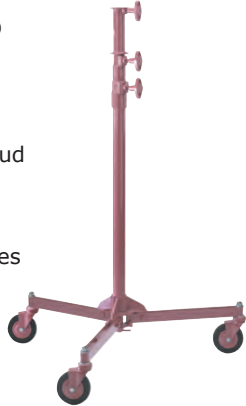

TYPE 500476 **JUNIOR SIZE STANDARD LITEWATE**

Liteweight version of standard heavy-duty Junoir Size Stand.

MOUNTING: 1¹/₈" dia. standard spud
EXTENSIONS: 2.
LOW: 44¹/₂ inches.
HIGH: 91 inches.
FOLDED FOR STORAGE: 41¹/₄ inches.
WEIGHT: 16¹/₂ lbs.
FINISH: Baked maroon enamel and clear anodize aluminum.
CASTERS: 4 inches



TYPE 1561 **JUNIOR SIZE SKI-HI**

Design to reach 37 inches above the Standard Size Junior Stand.

MOUNTING: 1¹/₈" dia. standard spud
EXTENSIONS: 2
LOW: 48 inches
HIGH: 137¹/₂ inches
FOLDED FOR STORAGE: 44¹/₂ inches
WEIGHT: 28¹/₂ lbs.
FINISH: Baked maroon enamel
CASTERS: 4 inches



TYPE 1411 **JUNIOR SIZE LOW**

A sturdy, shorter version of the Standard Size Junior Stand with one extension.

MOUNTING: 1¹/₈" dia. standard spud
EXTENSIONS: 1
LOW: 22¹/₄ inches
HIGH: 32 inches
FOLDED FOR STORAGE: 18⁷/₈ inches
WEIGHT: 18¹/₂ lbs.
FINISH: Baked maroon enamel
CASTERS: 4 inches





SENIOR STANDS

TYPE 418181 **SENIOR SIZE** **LITEWATE LOW**

A shorter version of the Senior Size Litewate Standard Stand.

MOUNTING: 1¹/₈" dia. standard spud
EXTENSIONS: 2
LOW: 35⁷/₈ inches
HIGH: 79³/₄ inches
FOLDED FOR STORAGE: 42¹/₂ inches
WEIGHT: 29³/₄ lbs.
FINISH: Satin bright nickel and clear anodize tubing, ball burnished aluminum castings and maroon enameled brass castings.
CASTERS: 5 inches



TYPE 418182 **SENIOR SIZE** **LITEWATE STANDARD**

A durable, quick folding lightweight stand. Ideal for studio and location use

MOUNTING: 1¹/₈" dia. standard spud
EXTENSIONS: 2
LOW: 43 inches.
HIGH: 102³/₄ inches.
FOLDED FOR STORAGE: 48³/₄ inches.
WEIGHT: 31 lbs.
FINISH: Satin bright nickel and clear anodize tubing, ball burnished aluminum castings and maroon enameled brass castings.
CASTERS: 5 inches



TYPE 418183 **SENIOR SIZE** **LITEWATE SKY-HI**

Sturdy design and light weight make it an ideal location stand. Folds into storage position with one easy motion. Curved locking shoes clamp extension securely in position. Unpainted surfaces are plated for long life. Easy rolling casters features neoprene tires and ball bearing swivels.

MOUNTING: 1¹/₈" dia. standard spud
EXTENSIONS: 3
LOW: 46¹/₈ inches
HIGH: 140⁷/₈ inches
FOLDED FOR STORAGE: 41¹/₄ inches
WEIGHT: 16¹/₂ lbs.
FINISH: Baked maroon enamel and clear anodize aluminum.
CASTERS: 5 inches

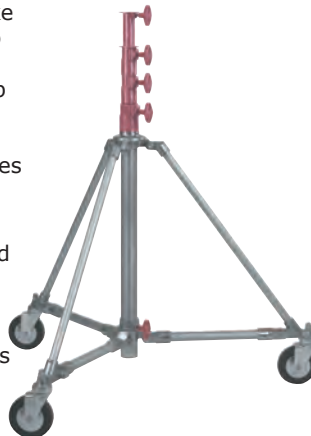

Folded for storage or transportation.



Mole-Richardson Co.

SENIOR/ WINDMACHINE STANDS

TYPE 41494

SENIOR SIZE STANDARD

A long lasting heavy-duty folding studio type stand.

MOUNTING: 1¹/₈" dia. standard spud

EXTENSIONS: 2

LOW: 43 inches

HIGH: 100 inches

FOLDED FOR STORAGE: 42 inches

WEIGHT: 37 lbs.

FINISH: Baked maroon enamel

CASTERS: 4 inches



TYPE 19720

SENIOR SIZE WINDMACHINE LOW

A low sturdy stand of steel tubing, brass castings and locking casters for use with Type 1971 Windmachine.

MOUNTING: 1¹/₈" dia. standard spud

EXTENSIONS: 1

LOW: 22¹/₄ inches

HIGH: 32 inches

FOLDED FOR STORAGE:

18⁷/₈ inches

WEIGHT: 20¹/₂ lbs.

FINISH: Baked maroon enamel

CASTERS: 4 inches—locking



TYPE 59746

SENIOR SIZE LONG LEG WINDMACHINE LOW

A low sturdy stand of steel tubing, brass castings and locking casters for use with Type 1971 Windmachine.

MOUNTING: 1¹/₈" dia. standard spud

EXTENSIONS: 1

LOW: 22¹/₄ inches

HIGH: 32 inches

FOLDED FOR STORAGE:

18⁷/₈ inches

WEIGHT: 23³/₄ lbs.

FINISH: Baked maroon enamel

CASTERS: 4 inches—locking

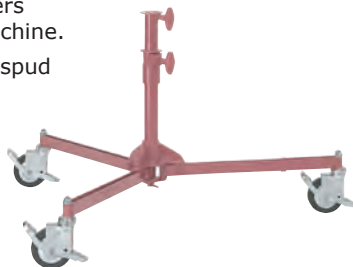



Mole-Richardson Co.

TYPE 75

COMET BOOM

FEATURES

The Comet Boom has a dual purpose. It may be used as a lamp boom or as a microphone boom by using the appropriate lamp mount or microphone attachments and microphone hangers. The Boom arm is adjustable and may be horizontally rotated 360° with the base locked in a stationary position. The vertical riser has an air brake for lowering boom arm.



Folded for storage



12

4



Mole-Richardson Co.

TYPE 75

COMET BOOM

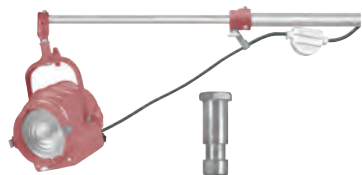

Type 7545 Lamp Mount

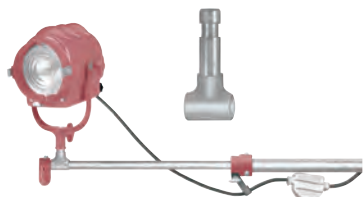

Type 7558 Fixed Spud Adapter non-swivel (factory assembled)

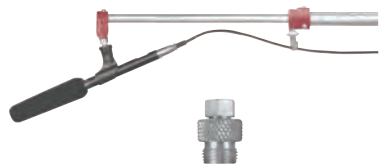

Type 7556 Microphone Hanger Adapter

SPECIFICATIONS

LAMP MOUNT:

TYPE 7545 1/8" dia. spud hung in rubber-insulated u-shaped yoke casting. Spud attaches to 1/4" - 20 male thread.

TYPE 7558 Fixed Spud Adapter-non-swivel with 5/8" dia. spud (factory assembled).

MICROPHONE ATTACHMENTS:

TYPE 7554 Microphone Hanger Stud with 5/16" - 18 threaded stud 1" long with wing nut and washer. Used to attach either Clamp Type or Stud Type Microphone Hanger. Attaches to 1/4" - 20 male thread.

TYPE 7556 Microphone Hanger Adapter consisting of the following:

Type 7535 Mike Hanger Nut with 5/8" - 27 male thread. Accepts variety of microphones, microphone adapters and fittings. Attaches to 1/4" - 20 male thread.

Type 7536 Microphone Hanger Nut with 5/8"- 27 female thread to 1/2" straight pipe thread. Attaches to Type 7535 Microphone Hanger Nut.

Accepts variety of microphones, such as Electro-Voice 635A.

Note: When ordering specify either Lamp Mount or Type of Microphone Attachment.

STAND HEIGHT:

LOW: 4 feet 11 7/8 inches to tilt axis.

HIGH: 8 feet 6 3/4 inches to tilt axis.

FOLDED FOR STORAGE: 5 feet 10 3/4 inches.

BOOM ARM LENGTH (Overall):

RETRACTED: 5 feet 3 3/4 inches.

EXTENDED: 8 feet 1 1/2 inches.

BOOM REACH: (Center of stand to lamp mounting spud): Adjustable from 3 feet 5 inches to 5 feet 4 inches with 8 3/4 pound Type 407 Baby Solarspot® and Boom counterweight in balance.

BOOM REACH: (Center of stand to microphone attachment): Adjustable from 4 feet 2 inches to 6 feet 6 inches with 1 1/2 pound microphone and Boom counterweight in balance.

FINISH: Arm castings and stand—baked maroon enamel. Arm and stand extension tube—satin finish chrome.

CASTERS: Locking, 4 inch neoprene-tired, ball bearing swivel, heavy-duty type.

WEIGHT: 67 1/2 pounds.

ACCESSORIES

- 7545 Lamp Mount
- 7554 Microphone Hanger Stud
- 7556 Microphone Hanger Adapter
- 7558 Fixed Spud Adapter — non swivel (factory assembled)

MICROPHONE HANGERS (Clamp Type with shock cords)

- H-1 1 7/8" to 2 1/8" dia. for Sennheiser MD-421.
- H-2 2 1/2" to 2 3/4" dia. for RCA 77DX, RCA 77-DX-G.
- H-5 3" to 3 1/2" dia. for Electro-Voice 667A or 668.
- H-7 1 3/8" dia. to 2 11/16" dia. for RCA BK-5B.
- H-8 5/8" to 1" dia. for Electro-Voice RE10, RE11 or RE15.

MICROPHONE HANGER (Stud Type with shock cords)

- H-4 For Altec 639A or B.



Type 7554 Microphone Hanger Stud



H-2 Microphone Hanger—Clamp Type



H-4 Microphone Hanger—Stud Type





Mole-Richardson Co.

TYPE 2751

LONG MOLEBOOM

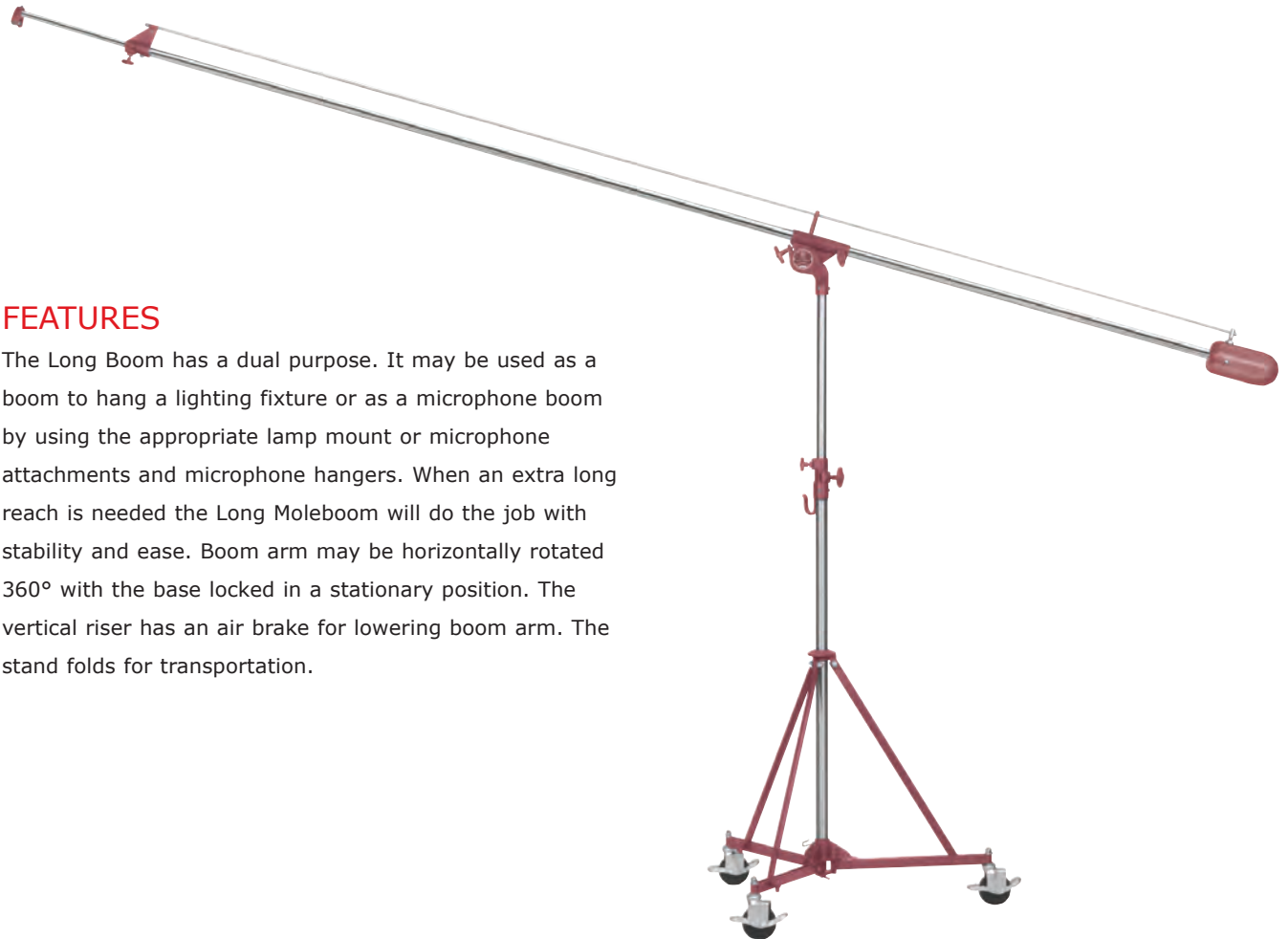

FEATURES

The Long Boom has a dual purpose. It may be used as a boom to hang a lighting fixture or as a microphone boom by using the appropriate lamp mount or microphone attachments and microphone hangers. When an extra long reach is needed the Long Moleboom will do the job with stability and ease. Boom arm may be horizontally rotated 360° with the base locked in a stationary position. The vertical riser has an air brake for lowering boom arm. The stand folds for transportation.

12

5



Mole-Richardson Co.

TYPE 2751 LONG MOLEBOOM

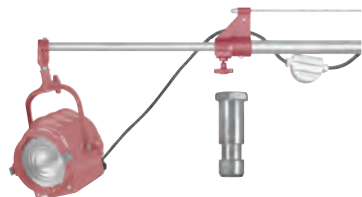
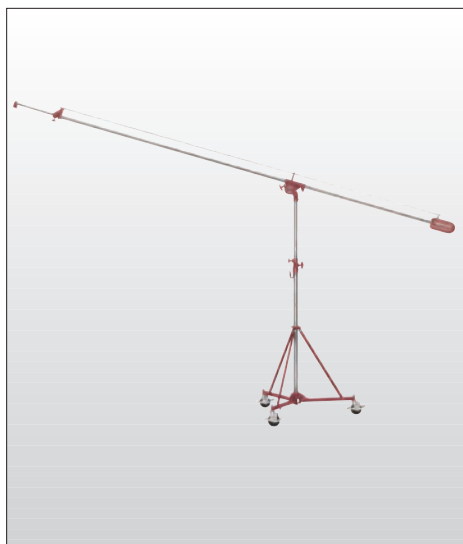

Type 7545 Lamp Mount

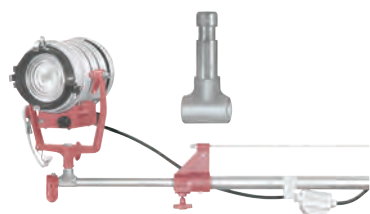

Type 27525 Fixed Spud Adapter non-swivel (factory assembled)



Type 7556 Microphone Hanger Adapter

SPECIFICATIONS

LAMP MOUNT:

TYPE 7545 1/8" dia. spud hung in rubber-insulated u-shaped yoke casting. Spud attaches to 1/4"—20 male thread.

TYPE 7558 Fixed Spud Adapter-non-swivel with 5/8" dia. spud (factory assembled)

MICROPHONE ATTACHMENTS:

TYPE 7554 Microphone Hanger Stud with 5/16"—18 threaded stud 1" long with wing nut and washer. Used to attach either Clamp Type or Stud Type Microphone Hanger. Attaches to 1/4"—20 male thread.

TYPE 7556 Microphone Hanger Adapter consisting of the following:

Type 7535 Mike Hanger Nut with 5/8"—27 male thread. Accepts variety of microphones, microphone adapters and fittings. Attaches to 1/4"—20 male thread.

TYPE 7536 Microphone Hanger Nut with 5/8"- 27 female thread to 1/2" straight pipe thread. Attaches to Type 7535 Microphone Hanger Nut. Accepts variety of microphones, such as Electro-Voice 635A.

Note: When ordering specify either Lamp Mount or Type of Microphone Attachment.

STAND HEIGHT:

LOW: 4 feet 11 7/8 inches to tilt axis.

HIGH: 8 feet 6 3/4 inches to tilt axis.

FOLDED FOR STORAGE: 5 feet 10 3/4 inches.

BOOM ARM LENGTH (Overall):

RETRACTED: 12 feet 6 1/2 inches.

EXTENDED: 15 feet 3 1/2 inches.

BOOM REACH: (Center of stand to lamp mounting spud):

Adjustable from 7 feet 5 1/4 inches to 9 feet 6 1/2 inches with 8 3/4 lbs. Type 407 Baby Solarspot® and Boom counterweight in balance.

BOOM REACH: (Center of stand to microphone attachment):

Adjustable from 8 feet 7 inches to 11 feet 1/2 inches with 1 1/2 lbs. microphone and Boom counterweight in balance.

FINISH: Arm castings and stand—baked maroon enamel. Arm and stand extension tube—satin finish chrome.

CASTERS: Locking, 4 inch neoprene-tired, ball bearing swivel, heavy-duty type.

WEIGHT: 95 1/2 lbs.

ACCESSORIES

7545 Lamp Mount

7554 Microphone Hanger Stud

7556 Microphone Hanger Adapter

7558 Fixed Spud Adapter — non swivel (factory assembled)

MICROPHONE HANGERS (Clamp Type with shock cords)

H-1 1 7/8" to 2 1/8" dia. for Sennheiser MD-421.

H-2 2 1/2" to 2 3/4" dia. for RCA 77DX, RCA 77-DX-G.

H-5 3" to 3 1/2" dia. for Electro-Voice 667A or 668.

H-7 1 3/8" dia. to 2 11/16" dia. for RCA BK-5B.

H-8 5/8" to 1" dia. for Electro-Voice RE10, RE11 or RE15.

MICROPHONE HANGER (Stud Type with shock cords)

H-4 For Altec 639A or B.



Type 7554 Microphone Hanger Stud



H-2 Microphone Hanger—Clamp Type



H-4 Microphone Hanger—Stud Type





Mole-Richardson Co.

TYPE 103B/TYPE 126B MICROPHONE BOOM AND PERAMBULATOR

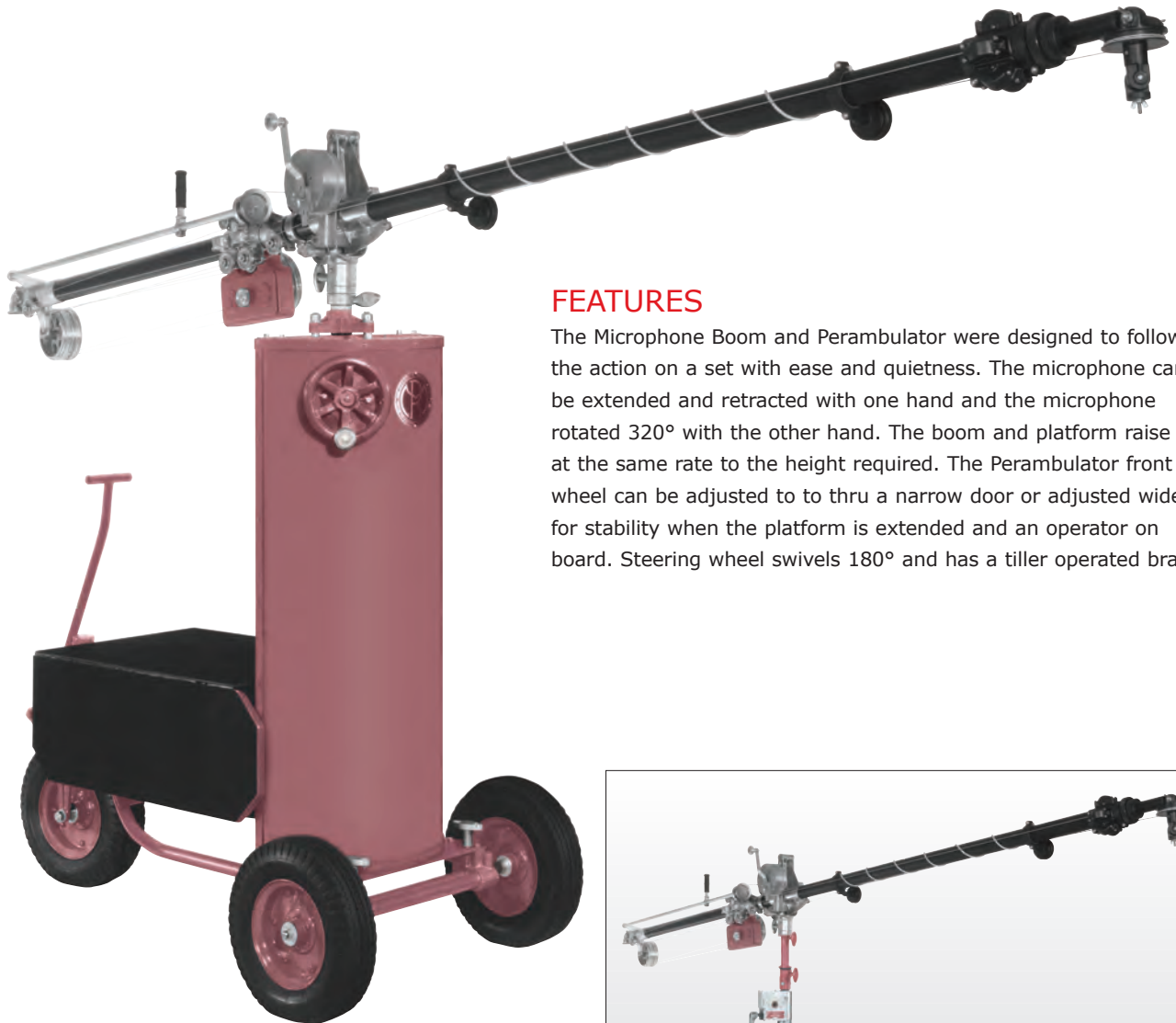

FEATURES

The Microphone Boom and Perambulator were designed to follow the action on a set with ease and quietness. The microphone can be extended and retracted with one hand and the microphone rotated 320° with the other hand. The boom and platform raise at the same rate to the height required. The Perambulator front wheel can be adjusted to go thru a narrow door or adjusted wider for stability when the platform is extended and an operator on board. Steering wheel swivels 180° and has a tiller operated brake.

12

6



Type 103B Microphone Boom
mounted on
Type 500572 Folding Crank-up Litewate Stand



Mole-Richardson Co.

TYPE 103B/TYPE 126B

MICROPHONE BOOM AND PERAMBULATOR



SPECIFICATIONS

BOOM: Type 103B.

CONSTRUCTION:

TUBES: Aluminum (two).

CASTING: All aluminum except cast iron counterweight box.

ROLLERS: Rubber (self-lubricating).

BEARINGS: Bronze (oil-impregnated), and grease packed ball bearings.

CONTROL CORDS: Natural linen (200 pound test).

BALANCE: Automatic counterbalancing during extension and retraction.

Nine lead weights in counterweight box allows adjustment needed with microphones of various weights.

MEASUREMENTS:

HEIGHT: 16³/₄ inches (less spud).

LENGTH OVERALL:

RETRACTED: 13 feet 2³/₄ inches.

EXTENDED: 22 feet 10³/₄ inches.

REACH: From trunnion to Mike Hanger.

Retracted: 7 feet 5 inches.

Extended: 17 feet 1 inch.

CONTROLS: Handle mounted on actuating rail provides 320° rotation of microphone. Handle mounted on grooved drum, provides positive control of extension and retraction of inner tube, controlling reach of microphone. Boom arm tilts vertically when trunnion clamp knob is released.

MICROPHONE MOUNT: Standard 5/16"–18 threaded stud 1" long with wing nut.

BOOM MOUNT: Aluminum trunnion casting with removable 1¹/₈" dia. steel yoke pin.

FINISH: Black anodized aluminum castings forward of trunnion and ball burnished aluminum castings to rear of trunnion. Tubes are black anodized. Counterweight is baked maroon enamel.

WEIGHTS:

BOOM: 71 pounds.

COUNTERWEIGHT BOX: 19¹/₂ pounds.

LEADWEIGHTS: Nine at 1³/₄ pounds each.

PERAMBULATOR: Type 123B.

CONSTRUCTION:

FRAME: Steel tubing, solid sheet steel, brass and bronze castings.

PLATFORM: Drop-leaf platform of heavy sheet steel covered with corrugated rubber. Pull-out bars support platform leaves.

WHEELS: Pressed steel with 4.80/4.00 x 8 pneumatic tires. Rear wheels adjust in overall width from 29 inches to 49⁵/₈ inches. Front wheels swivels 180°.

ELEVATING COLUMN: Accepts 1¹/₈" dia. yoke pin. Automatic braking of mechanical riser upon release of handle of elevating wheel. Boom and platform raise and lower together. Distance from Boom to platform adjustable to operator height.

MEASUREMENTS:

LOW: 5 feet 2¹/₄ inches.

HIGH: 8 feet 6¹/₂ inches.

LENGTH: 5 feet 3¹/₂ inches.

WIDTH: 2 feet 5 inches. Wheels adjust to 4 feet 2 inches.

PLATFORM:

LOW: 2 feet 2 inches.

HIGH: 4 feet 9 inches.

FINISH: Baked maroon enamel.

WEIGHT: 405 pounds.

ACCESSORIES

MICROPHONE HANGERS (Clamp Type with shock cords)

H-1 1⁷/₈" to 2¹/₈" dia. for Sennheiser MD-421.

H-2 2¹/₂" to 2³/₄" dia. for RCA 77DX, RCA 77-DX-G.

H-5 3" to 3¹/₂" dia. for Electro-Voice 667A or 668.

H-7 1³/₈" dia. to 2¹¹/₁₆" dia. for RCA BK-5B.

H-8 5/8" to 1" dia. for Electro-Voice RE10, RE11 or RE15.

MICROPHONE HANGER (Stud Type with shock cords)

H-4 For Altec 639A or B.



H-2 Microphone Hanger—Clamp Type



H-4 Microphone Hanger—Stud Type

